

# MODEL STOPER SB S1

## TECHNICAL FEATURES OF A SINGLE-COIL BOILER MODEL SB S1

Volume L	1500	2000
Electric heater power kW	3 x 7,5	4 x 7,5
Coil heat exchanging surface m <sup>2</sup>	3	4
Cold water input G	2 x 1 1/2"	2 x 1 1/2"
Hot water outlet G	2 x 1 1/2"	2 x 1 1/2"
Recirculation G	1"	1"
Weight kg enamel	540	700
Weight kg CrNi	400	500
Working pressure bar	8	8

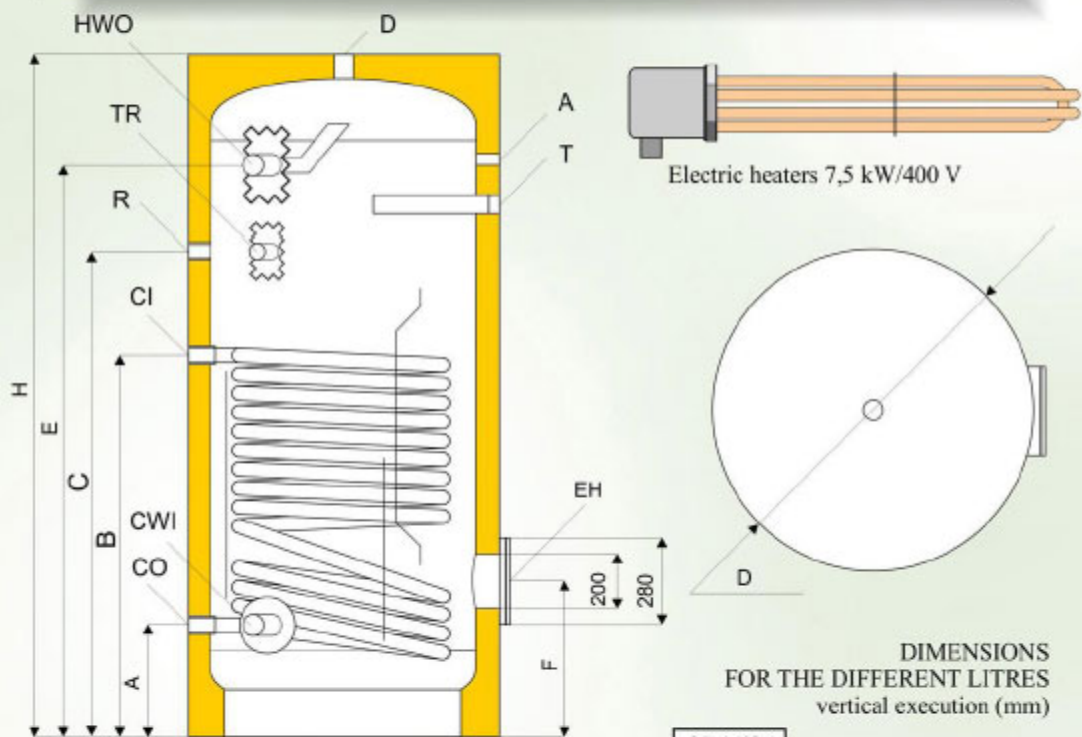

DIMENSIONS  
FOR THE DIFFERENT LITRES  
vertical execution (mm)

SB V/S1	1500 L	2000 L
A	355	355
B	1085	1085
C	1623	1623
E	1845	1845
D	φ1200	φ1350
H	2240	2200
F	475	475



Thermal regulator

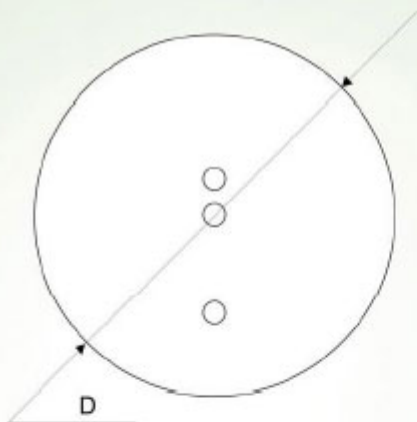
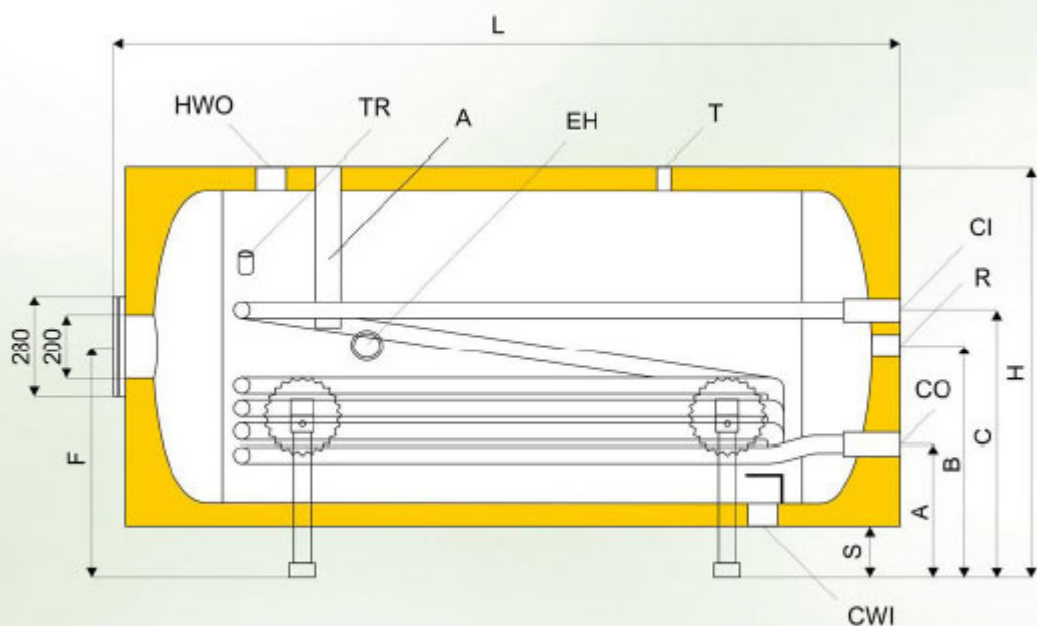

Thermal regulator

DIMENSIONS  
FOR THE DIFFERENT LITRES  
horizontal execution (mm)

SB H/S1	1500 L	2000 L
A	450	480
B	740	820/940
C	850	480
D	φ1200	φ1350
L	2240	2200
F	740	815
S	140	140
H	1340	1490

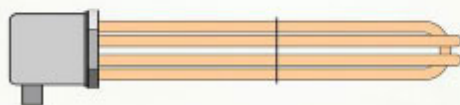

Electric heaters 7,5 kW/400 V

